

Autonomous Mobile Robot

OMRON MD Series AMR

The world's most innovative mobile robot solution

1933

Omron established

210

Locations Worldwide

4000+

mobile robots
deployed globally

20+

years of
robotics experience

OMRON mobile robots are autonomous mobile robots (AMRs) designed to dramatically increase productivity in manufacturing and logistics operations by increasing throughput, eliminating errors and improving material traceability.

The MD Series offers industry innovations with

- 650 kg or 900 kg medium capacity payload
- Dynamic intelligent 360° safety
- Integrated automation controller

Omron offers a complete family of mobile robots to provide scalability and large-scale fleet management

- Best-in-class navigation and safety
- Best-in-class fleet management
- Easy integration and scalability



Medium Duty Ideal Capacity

The OMRON Medium-Duty (MD) series of mobile robots provides more options moving more material.

The OMRON MD Series offers a mid-range payload capacity ranging from 650 kg to 900 kg. The medium-range payload capacity to provide customers with more options for transporting parts and products around their facility. The size allows for use with European, US, and Asian pallet sizes. The payload of the MD Series makes it an ideal choice for pallet-moving applications where pickup and drop-off stands can be used, reducing the need for equipment as well as the risk of injury. All OMRON mobile robots can be managed on the OMRON Fleet Manager platform, which is capable of controlling up to 100 mobile robots, so users can manage OMRON LD-60/90, LD-250, MD-650, MD-900, and HD-1500 mobile robots from a single, enterprise-level system.

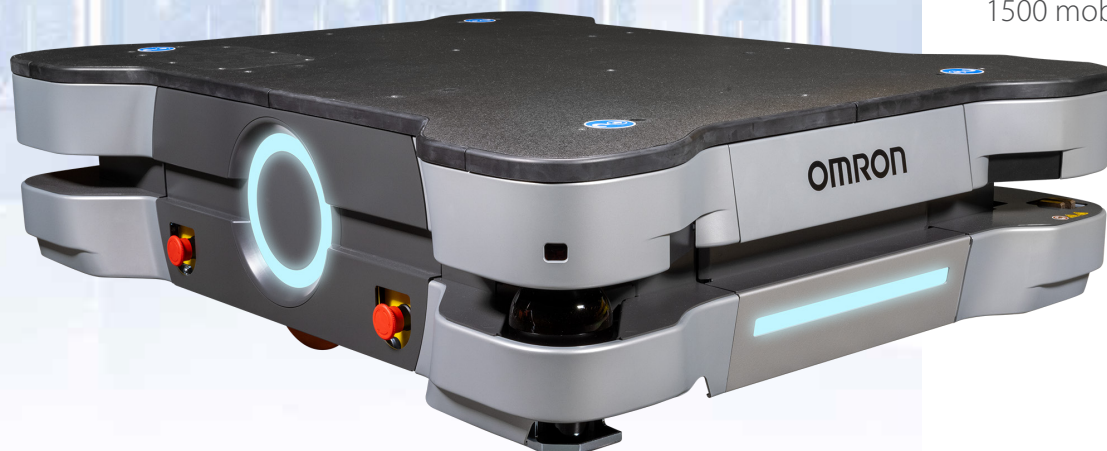

Dynamic Intelligent Safety

Omron mobile robots feature an innovative 360° safety system as well as an optional 180° patented vertical scanners. The intelligent safety system dynamically shifts between 70+ safety zones and patterns based on speed and rotation. The dynamic intelligent safety benefits users with increased safety performance, increased speed, and reduced false speed reduction or stops.

Integrated safety system includes:

- OMRON NX-SL5 safety controller
- Avoids static and moving obstacles
- Redundant safety motion control
- Expandable safety-rated system for additional I/O, scanners, and sensors
- Fully compliant with ISO 3691-4 and ANSI/RIA R15.08 standards



Front and rear safety patterns

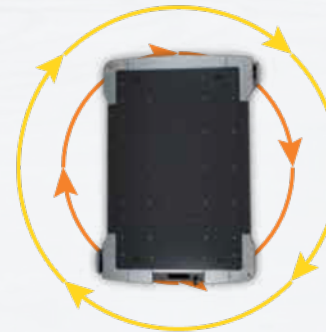

360° in-place safety pattern

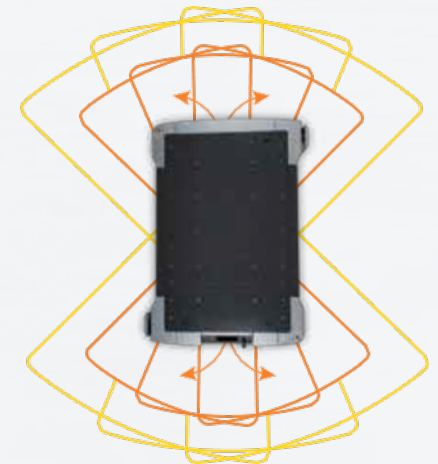

Dynamic safety patterns based on speed and direction

■ Safety Zone

■ Warning Area

AMRs vs AGVs

Automated guided vehicles (AGVs) require a predefined path to follow, either a network of magnetic lines on the floor or beacons on the walls. So although AGVs allow modifications to production lines, facilities will need to install new equipment every time the AGV path is changed, leading to downtime and extra costs.

Automated Mobile Robots (AMRs) can safely navigate without the use of floor magnets or wall-mounted beacons. An AMR will first create a baseline map of a facility using built-in sensors, then will constantly detect its surroundings. When processes change, AMRs can easily change as well, creating networks of new routes or being reassigned to new tasks.

	OMRON AMR	AGV
Set Up	Ready to go after simple mapping	Requires navigation guides
Navigation	Navigates autonomously and safely without physical guides	Needs guides, such as floor magnets or beacons
Obstacles	Safely avoids obstacles without stopping	Stops at obstacles and remains still until obstacles are removed
Map Changes	Easy	Factory Modifications
Changing Destinations	Easy	Factory Modifications
Scalability	Easy	Factory Modifications

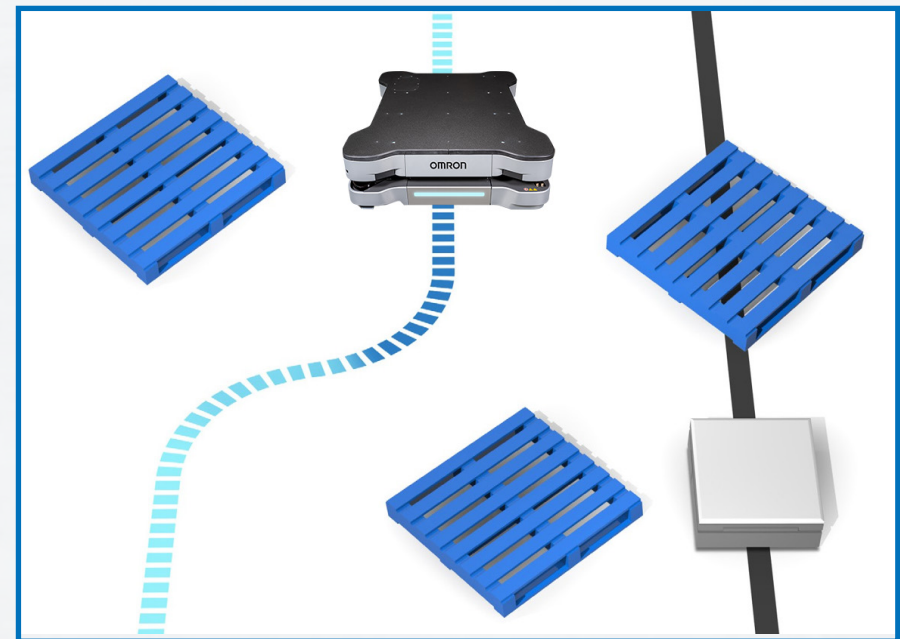

Unlike autonomous mobile robots (AMRs), automated guided vehicles (AGVs) require guides, which restricts their options for routing.

Product Features



Flexible Functionality

OMRON's mobile robot solutions provide best-in-class versatility and can perform a wide variety of material handling tasks. We're also scalable, so we can grow along with your business and automation needs.

The MD-650 boasts a class-leading top speed of 2.2 meters/second and the MD-900 comes in at 1.8 meters/second. Leveraging advanced battery and charging technologies, the MD Series provides eight hours of runtime with a charging time of less than 30 minutes for a industry-best 16:1 uptime ratio.



Powerful Fleet Management

The OMRON Fleet Operations Workspace (FLOW) Core solution provides an intelligent fleet management system that monitors mobile robot locations, traffic flow, and job requests, ensuring your factory operates at peak efficiency.

The FLOW Core solution also reduces programming in your manufacturing execution system (MES) or enterprise resource planning (ERP) system by automating robot tasks.

Key Functions

- Displays robot location and status
- Displays Job queue
- Prioritizes important jobs
- Selects fastest routes based on human and robot traffic
- Identifies blocked paths and creates alternative routes
- Optimizes job assignments
- Optimizes battery charging

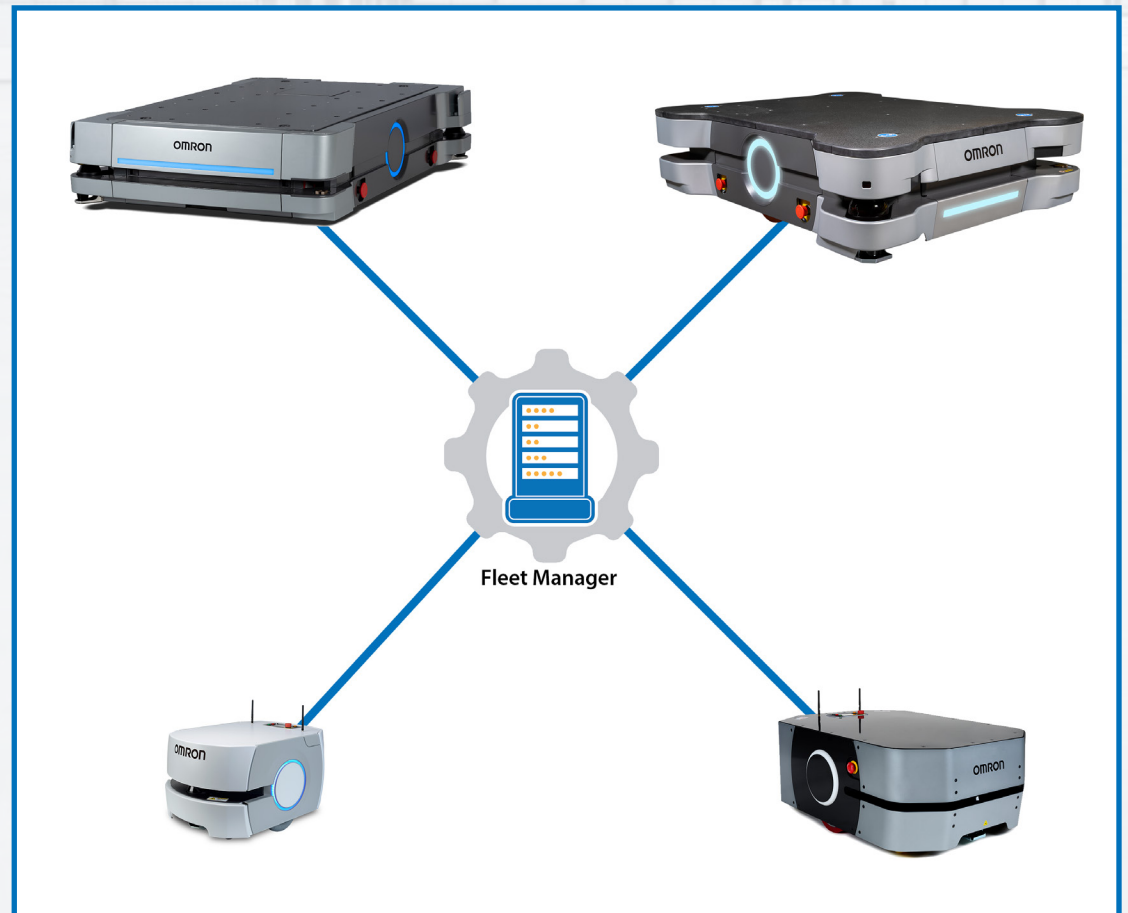

FLOW iQ Fleet Operations Workspace iQ

FLOW iQ enhances the core user experience with powerful data collection and analytics through an intuitive user interface. Powerful visualization tools can generate graphics in real time. Information such as fault maps, robot path maps, robot utilization statistics give users the data they need to track and optimize their operations with quick and easy set up.

Key Functions

- Quickly view robot status to monitor work to idle ratio and maximize productivity
- Visualize the impact of facility changes with the Localization Map
- Diagnose tricky network issues with the wireless diagnostics tools
- Track robot health with the fault map overlay over other analytics to find patterns
- Tailor fleet traffic with the Position Density Map to maximize cycle time and minimize time wasted in lockups

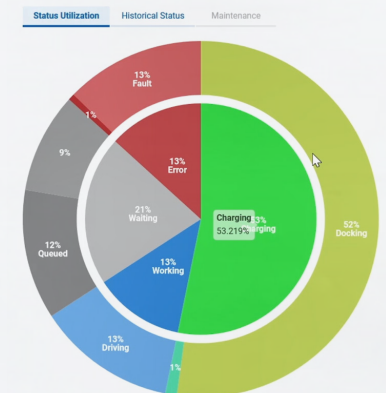
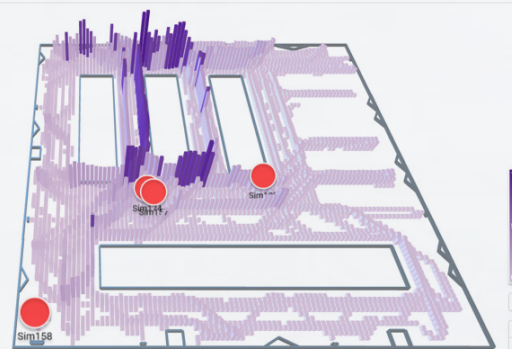

OMRON Fleet Management Solutions

Optimize Efficiency

1. Intelligent Job Assignment

Reduces wasted time and movement by continuously looking ahead to anticipate which robots will be best positioned for upcoming tasks.

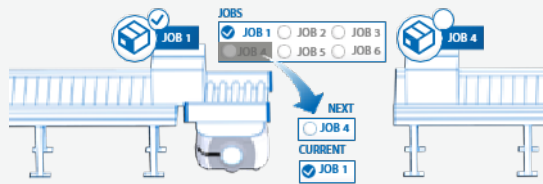

2. Managed Motion

Ensures smooth operations in busy environments by coordinating traffic flows and efficiently sequencing pick-up and drop-off at target locations.

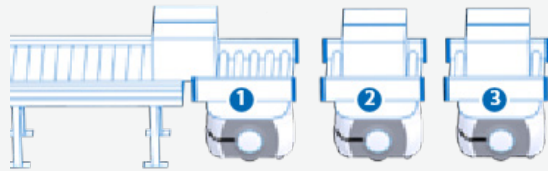

3. Traffic Control

Notifies converging robots of their predicted paths, allowing them to recalculate and avoid collision in the most efficient way.

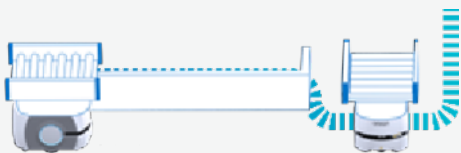

Maximize Uptime

4. Automatic Updates

Performs updates automatically across the entire fleet



5. Charge Management

Tracks battery power of the entire fleet, directing robots to their nearest available, or preferred docking station on a schedule that ensures continuous fleet operation.

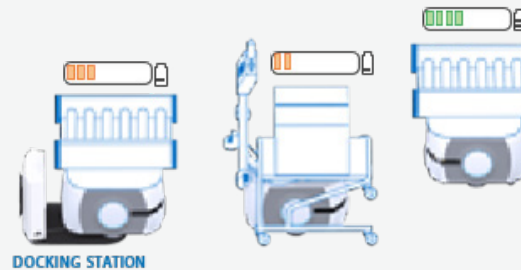

Increase Flexibility

6. Easy Integration with IT Systems

Fleet Manager can connect to your MES, ERP, and WMS so that jobs can be propagated automatically to the fleet in real time.

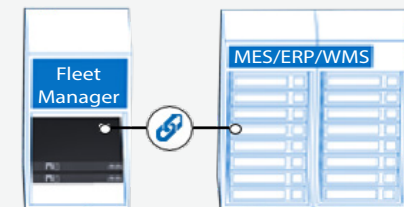

7. Skill Administration

Understands the capabilities of each vehicle in the fleet, and always makes sure that the right job is assigned to the right robot.

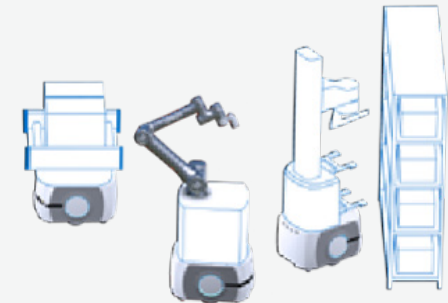

8. Easy-to-call Robots

Easily call a robot to a location using the OMRON Mobile I/O Box or Tablet

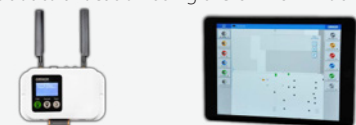

OMRON Mobile Solution

OMRON supplies more than robots. We deliver a full ecosystem of automation technology to provide the best solution from one source. Fleet Operations Workspace is the software platform that puts you in complete control of your mobile robot workforce, improving productivity, throughput, and traceability.

Our Cell Alignment Positioning System (CAPS) uses markers to more effectively align robots at goals for better drop-offs and pick-ups.

Our patented Acuity Drive generates navigation markers from ceiling lights and objects to help identify positions of the robots, no matter how frequently the environment on the floor changes.

OMRON Fleet Analytics Engine stores fleet data and allows you to replay fleet activities.

OMRON Fleet Simulator easily simulates fleets of robots so you can fine-tune your fleet before deployment.

OMRON Fleet Manager coordinates mobile robots and provides traceability, job allocation, and traffic control across the entire fleet. A second Fleet Manager can also provide backup functionality.

With a payload of 1500 kg, the HD-1500 is designed to transport heavy duty payloads.

Our customers can add manipulation to their mobile fleet by integrating our LDs with our Omron TM Collaborative Robots.

Our PC- and tablet-based software interface helps you manage your fleet.

The MD Series has a payload of 650 kg or 900 kg and provides the perfect blend of power and maneuverability.

Enhanced security allows safe and easy integration into IT systems, including MES and WRP systems.

With payloads of 60, 90, and 250 kg, the LD series is the industry standard for Autonomous Mobile Robots (AMRs).

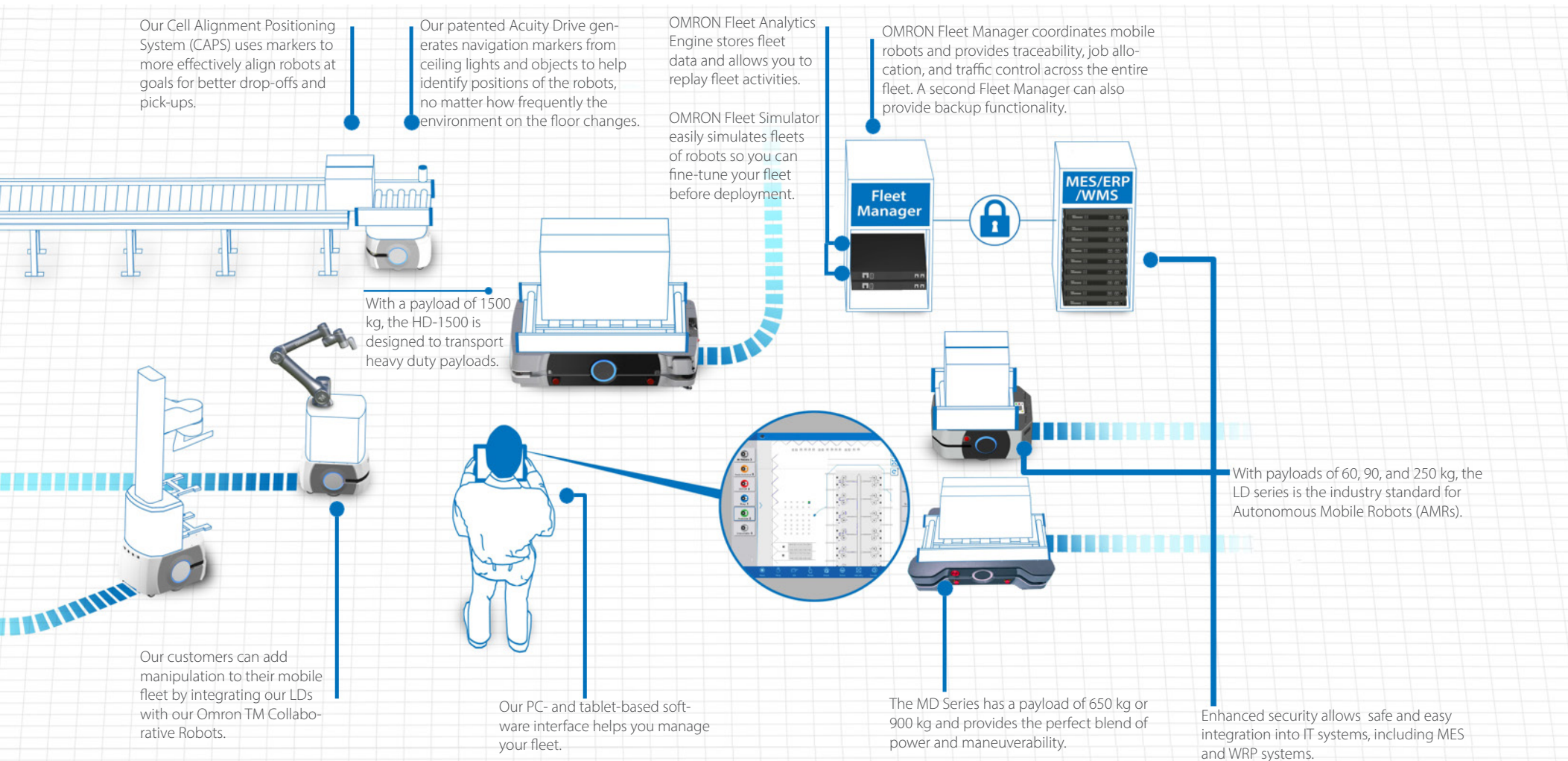

Industrial Automation Solution

You need more than a piece of advanced hardware equipment; you need an autonomous material transport system flexible enough to evolve with changing needs. The Omron full family of automation technology fills in your entire production line.

As the leader in industrial automation, Omron offers products that help manufacturers fulfill the needs of mass customization, and address issues related to rising labor costs and labor shortages.

Along with mobile robots, Omron provides a variety of automation equipment and devices that range from control components and vision sensors to controllers and servomotors, as well as an array of safety devices and fixed robots.

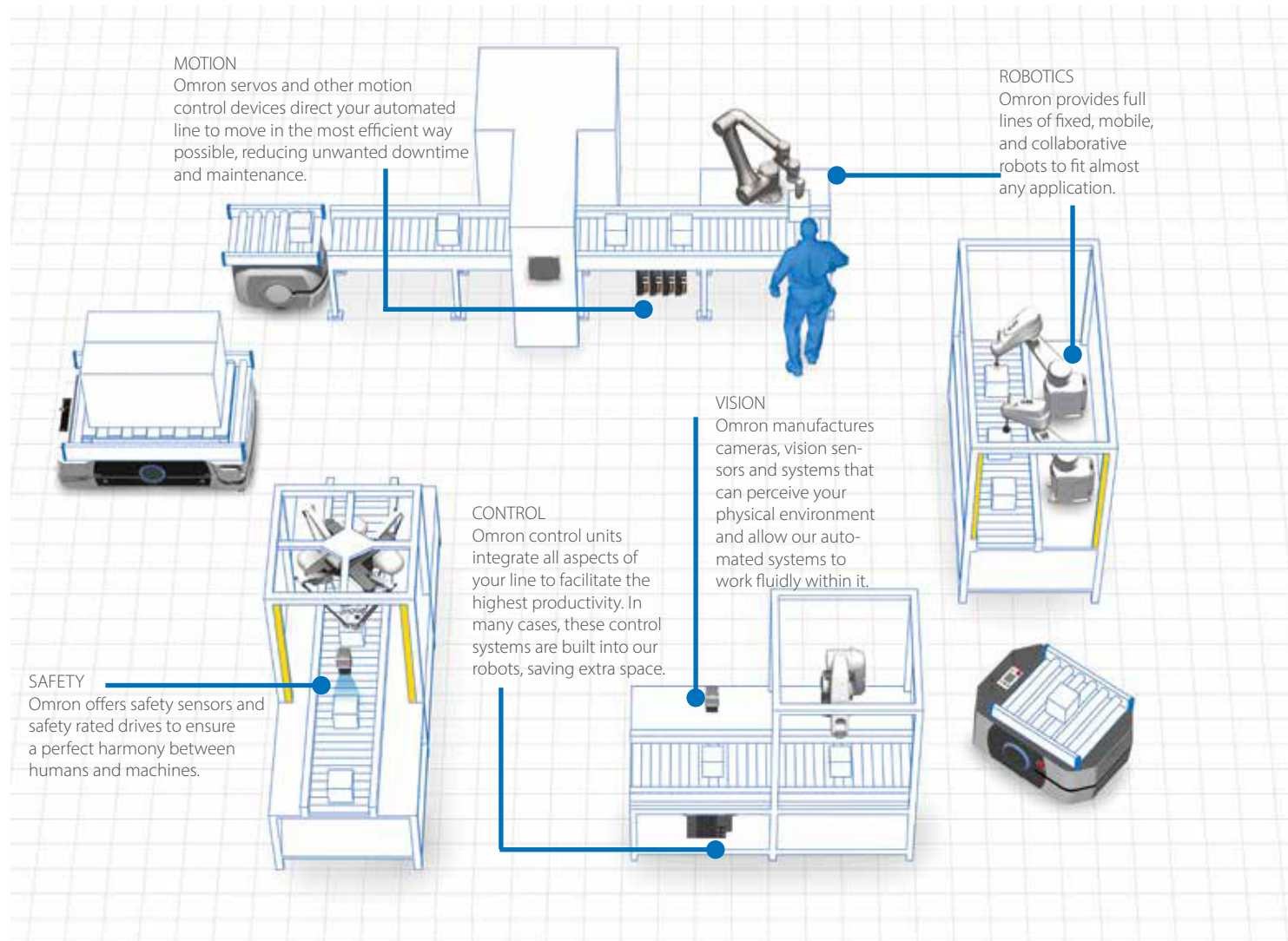

Your trusted partner in automation

When you work with Omron, you don't just get a robot — you get a fully integrated solution to meet the needs of your automated production.



Integrated

Integrates with custom payloads
such as conveyors
Compatible with other OMRON Robots

Intelligent

One fleet manager controls up to 100 robots
Intuitive setup on PCs and tablets
Works safely with people

Interactive

Optimizes routing
Adapts to changing conditions on the fly

Made for Industry

As an industry leading provider of robotics and automation systems, Omron mobile robots are deployed in thousands of applications across multiple industries.



Environmental Mobility

- Tire assembly
- Automotive electronics
- Automotive accessories
- Assembly and inspection

Digital

- Semiconductor wafer manufacturing
- Semiconductor packaging and testing
- Mobile device manufacturing
- Solar panel manufacturing

Food & Household Goods

- Stockroom transport
- Transport goods to assembly and sorting stations
- Scrap and refuse removal

Medical

- Sterilization room transport
- Laboratory sample transport

Logistics

- Material handling
- Parts transfer
- Non-conforming goods handling
- Reduced use of forklifts

Global service and support network

Omron offers service and support for its mobile solutions almost anywhere in the world, ensuring our solutions will run with minimal unwanted downtime.

150+ Locations,
40+ Countries

North America
& South America
10+ locations

- Local Offices
- Extended Support Available

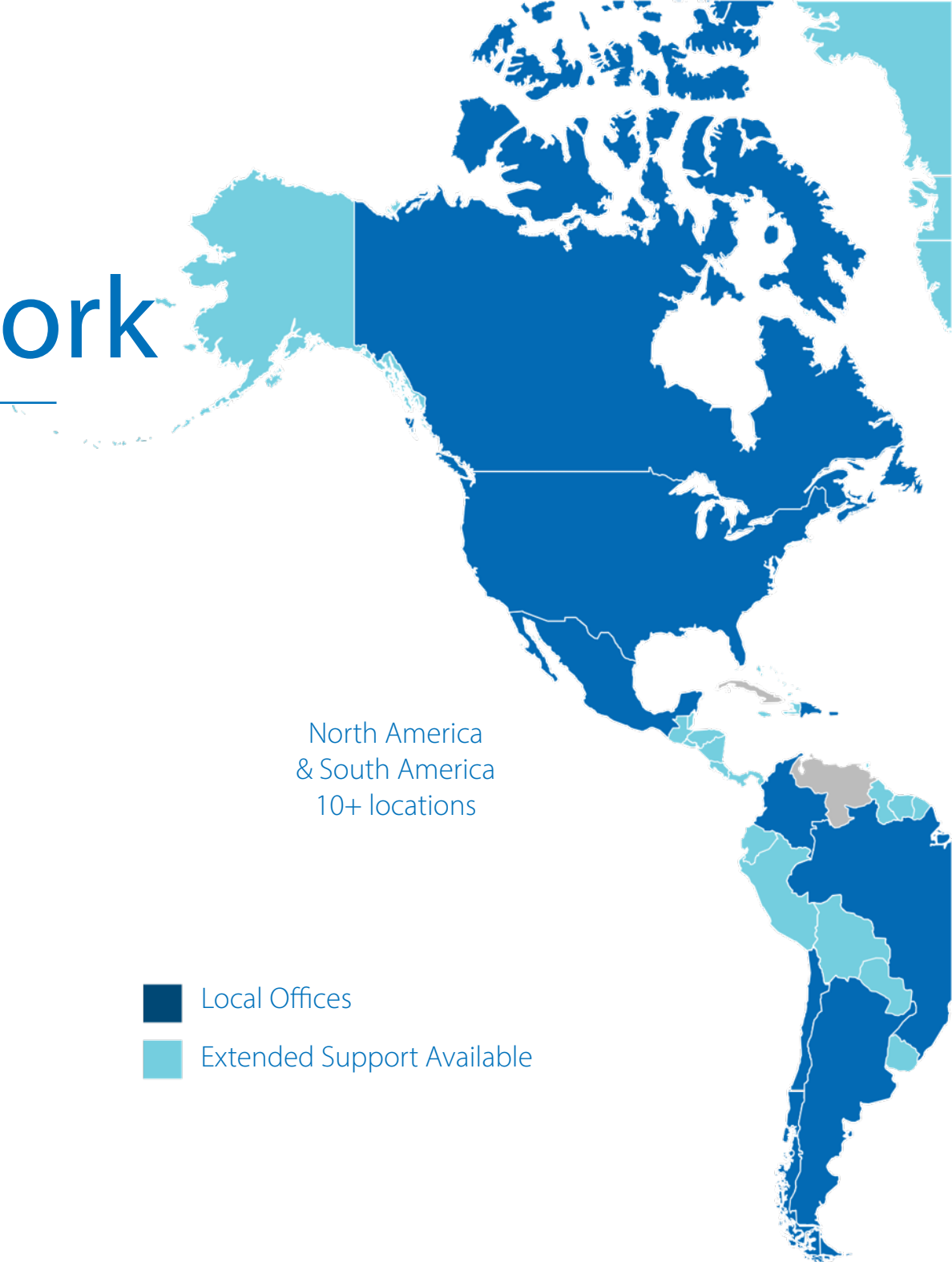

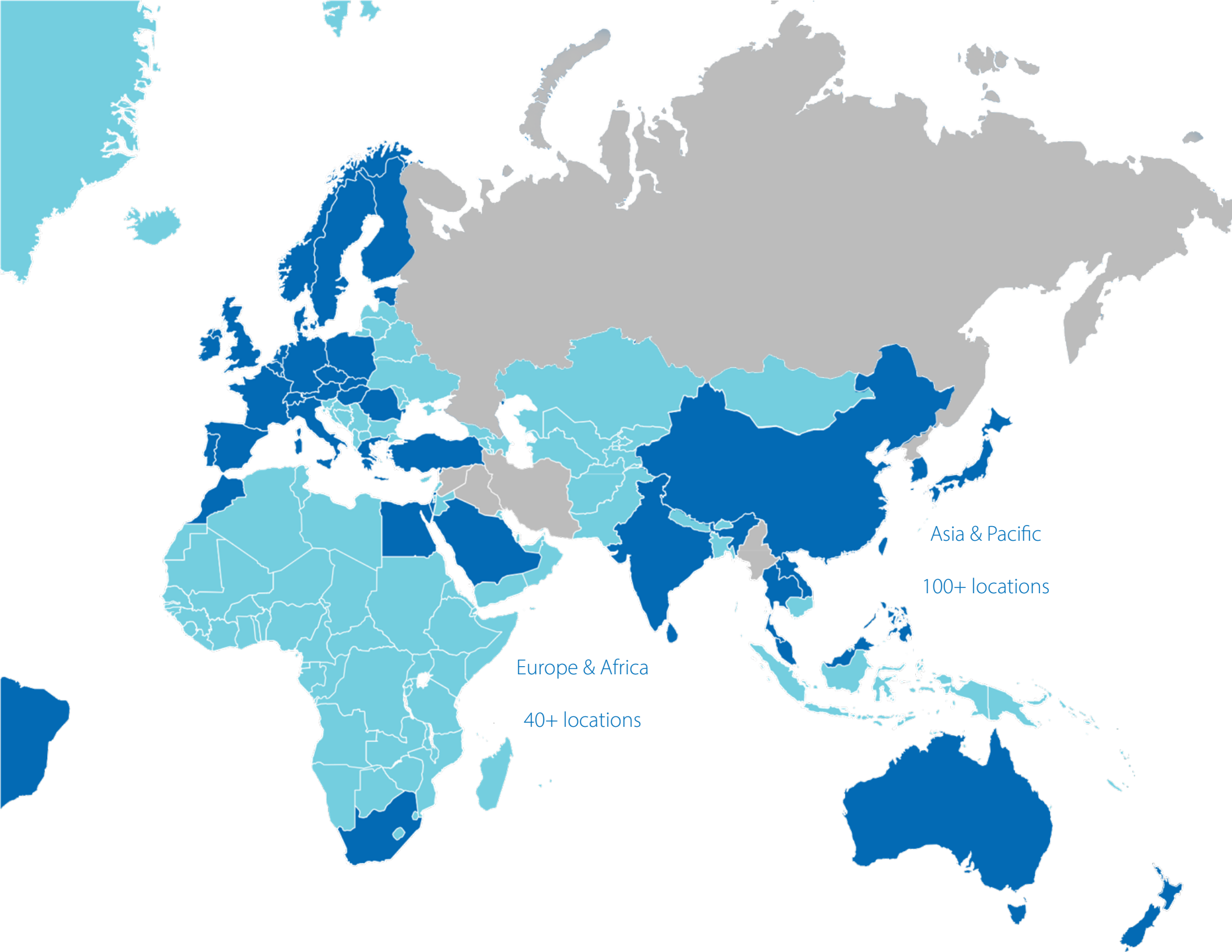

Asia & Pacific
100+ locations

Europe & Africa
40+ locations

OMRON Corporation

Kyoto, JAPAN

Industrial Automation Company

Contact: www.ia.omron.com

OMRON ROBOTICS AND SAFETY TECHNOLOGIES, INC.

4225 Hacienda Drive,
Pleasanton, CA 94588 U.S.A.
Tel: (1) 925-245-3400/Fax: (1) 925-960-0590

OMRON AUTOMATION AMERICAS

2895 Greenspoint Parkway, Suite 200
Hoffman Estates, IL 60169 U.S.A.
Tel: (1) 847-843-7900/Fax: (1) 847-843-7787

OMRON EUROPE B.V.

Wegalaan 67-69, 2132 JD Hoofddorp
The Netherlands
Tel: (31)2356-81-300/Fax: (31)2356-81-388

OMRON (CHINA) CO., LTD.

Room 2211, Bank of China Tower, 200 Yin Cheng Zhong Road, PuDong
New Area, Shanghai, 200120, China
Tel: (86) 21-5037-2222/Fax: (86) 21-5037-2200

OMRON ASIA PACIFIC PTE. LTD.

No. 438A Alexandra Road # 05-05/08 (Lobby 2),
Alexandra Technopark, Singapore 119967
Tel: (65) 6835-3011/Fax: (65) 6835-2711

OMRON ELECTRONICS KOREA CO., LTD.

18Floor, Kyobo Tower B Wing, 465, Gangnam-daero
Seocho-Gu, Seoul, Republic of Korea
Tel: (82) 70-4506-4106/Fax: (82) 2-3483-7788

OMRON AUTOMATION PRIVATE LIMITED

THE QUBE 5th Floor, Unit No. 501 - 504, M V Road, Marol
Andheri (EAST), Mumbai -MH-400059, India
Tel: (91) 22-7128-8400/Fax: (91) 22-7128-8401

OMRON TAIWAN ELECTRONICS INC.

6F,Home Young Budg.,No.363,Fu-Shing N.Road
Taipei, Taiwan R.O.C
Tel: (886) 2-2715-3331/Fax: (886) 2-2712-6712